

Installation Note

Source Attenuators and Bias Tees Upgrade Kit

For E8363B and E8364B PNA Series Microwave Network Analyzers

Network Analyzer Model Number	Upgrade Kit Part Number
E8363B and E8364B	E8364-60108



Agilent Part Number: E8364-90025

Printed in USA September 2007

Supersedes print date: April 2007

© Agilent Technologies, Inc. 2003, 2005, 2007



E8364-90025

WARRANTY STATEMENT

THE MATERIAL CONTAINED IN THIS DOCUMENT IS PROVIDED “AS IS,” AND IS SUBJECT TO BEING CHANGED, WITHOUT NOTICE, IN FUTURE EDITIONS. FURTHER, TO THE MAXIMUM EXTENT PERMITTED BY APPLICABLE LAW, AGILENT DISCLAIMS ALL WARRANTIES, EITHER EXPRESS OR IMPLIED WITH REGARD TO THIS MANUAL AND ANY INFORMATION CONTAINED HEREIN, INCLUDING BUT NOT LIMITED TO THE IMPLIED WARRANTIES OF MERCHANTABILITY AND FITNESS FOR A PARTICULAR PURPOSE. AGILENT SHALL NOT BE LIABLE FOR ERRORS OR FOR INCIDENTAL OR CONSEQUENTIAL DAMAGES IN CONNECTION WITH THE FURNISHING, USE, OR PERFORMANCE OF THIS DOCUMENT OR ANY INFORMATION CONTAINED HEREIN. SHOULD AGILENT AND THE USER HAVE A SEPARATE WRITTEN AGREEMENT WITH WARRANTY TERMS COVERING THE MATERIAL IN THIS DOCUMENT THAT CONFLICT WITH THESE TERMS, THE WARRANTY TERMS IN THE SEPARATE AGREEMENT WILL CONTROL.

DFARS/Restricted Rights Notice

If software is for use in the performance of a U.S. Government prime contract or subcontract, Software is delivered and licensed as “Commercial computer software” as defined in DFAR 252.227-7014 (June 1995), or as a “commercial item” as defined in FAR 2.101(a) or as “Restricted computer software” as defined in FAR 52.227-19 (June 1987) or any equivalent agency regulation or contract clause. Use, duplication or disclosure of Software is subject to Agilent Technologies’ standard commercial license terms, and non-DOD Departments and Agencies of the U.S. Government will receive no greater than Restricted Rights as defined in FAR 52.227-19(c)(1-2) (June 1987). U.S. Government users will receive no greater than Limited Rights as defined in FAR 52.227-14 (June 1987) or DFAR 252.227-7015 (b)(2) (November 1995), as applicable in any technical data.

Safety Notes

The following safety notes are used throughout this document. Familiarize yourself with each of these notes and its meaning before performing any of the procedures in this document.

WARNING	Warning denotes a hazard. It calls attention to a procedure which, if not correctly performed or adhered to, could result in injury or loss of life. Do not proceed beyond a warning note until the indicated conditions are fully understood and met.
----------------	---

CAUTION	Caution denotes a hazard. It calls attention to a procedure that, if not correctly performed or adhered to, could result in damage to or destruction of the instrument. Do not proceed beyond a caution sign until the indicated conditions are fully understood and met.
----------------	---

Getting Assistance from Agilent

By internet, phone, or fax, get assistance with all your test and measurement needs.

Contacting Agilent

Assistance with test and measurements needs and information on finding a local Agilent office are available on the Web at:

www.agilent.com/find/assist

If you do not have access to the Internet, please contact your Agilent field engineer.

NOTE In any correspondence or telephone conversation, refer to the Agilent product by its model number and full serial number. With this information, the Agilent representative can determine whether your product is still within its warranty period.

About Installing the Upgrade Kit

IMPORTANT Option UNL can only be installed on analyzers with the option combinations listed below as “Products affected”. If your analyzer does not have the proper options (as listed below), it will be necessary to install those options BEFORE installing this option (Option UNL).

Products affected.	E8363/4B; without Option 014 E8363/4B; Option 014 (without Option 081) E8363/4B; Options 014 and 081
Installation to be performed by	Agilent service center or personnel qualified by Agilent
Estimated installation time	2.0 hours
Estimated adjustment time	0.5 hours
Estimated full instrument calibration time	4.5 hours

Description of Option UNL

This option adds a 60-dB step attenuator and a bias tee between the switch splitter and each of the front panel test ports.

The step attenuators are used to adjust the power level to the device under test (DUT) without changing the power in the reference path.

The bias tees provide a means of biasing active devices under test. DC bias for the bias tees is provided through two rear-panel BNC connectors. These inputs are fused for protection.

Items Included in the Upgrade Kit

Check the contents of your kit against this list. If any item is missing or damaged, contact Agilent Technologies. Refer to [“Getting Assistance from Agilent”](#) on page 3.

Table 1 Contents of Option UNL Upgrade Kit (E8364-60108)

Ref. Desig.	Description	Qty	Part Number
These parts are for all analyzers			
	Installation note (this document)	1	E8364-90025
	Machine screw, M3.0 x 8 CWPNTX (for attaching attenuators)	4	0515-0372

Table 1 Contents of Option UNL Upgrade Kit (E8364-60108)

Ref. Desig.	Description	Qty	Part Number
	Machine screw, M2.5 x 14 CWPNTX (for attaching bias tees)	4	0515-2141
	Cable clamp	1	1400-1439
A36, A37	60-dB step attenuator	2	33325-60012
A38, A39	Bias tee (cable included)	2	5087-7239
	Ribbon cable (for A36 step attenuator)	1	8121-0819
	Ribbon cable (for A37 step attenuator)	1	8121-0119
W51	RF cable, A22 switch splitter to A36 step attenuator	1	E8364-20055
W52	RF cable, A22 switch splitter to A37 step attenuator	1	E8364-20056
W55	RF cable, A38 bias tee to A25 test port 1 coupler	1	E8364-20167
W56	RF cable, A39 bias tee to A26 test port 2 coupler	1	E8364-20168
These parts are for analyzers WITHOUT Option 014			
W7	RF cable, channel R1 attenuator to A28 channel R1 mixer	1	E8364-20174
W8	RF cable, channel R2 attenuator to A29 channel R2 mixer	1	E8364-20175
W53	RF cable, A36 step attenuator to A38 bias tee	2	E8364-20077
W54	RF cable A37 step attenuator to A39 bias tee		
These parts are for analyzers WITH Option 014 but WITHOUT Option 081			
	Lower front panel overlay (Option UNL/014)	1	E8364-80011
W70	RF cable, REFERENCE 1 RCVR R1 IN to A28 channel R1 mixer	1	E8364-20176
W71	RF cable, REFERENCE 2 RCVR R2 IN to A29 channel R2 mixer	1	E8364-20177
W81	RF cable, A36 step attenuator to PORT 1 SOURCE OUT	1	E8364-20053
W82	RF cable, A37 step attenuator to PORT 2 SOURCE OUT	1	E8364-20054
W83	RF cable, PORT 1 CPLR THRU to A38 bias tee	1	E8364-20039
W84	RF cable, PORT 2 CPLR THRU to A39 bias tee	1	E8364-20040
These parts are for analyzers WITH Option 014 AND Option 081			
	Lower front panel overlay (Option UNL/014)	1	E8364-80011
W67	RF cable, A25 test port 1 coupler to PORT 1 CPLR ARM	1	E8364-20043
W68	RF cable, A26 test port 2 coupler to PORT 2 CPLR ARM	1	E8364-20044
W71	RF cable, RCVR R2 IN to A29 channel R2 mixer	1	E8364-20155
W81	RF cable, A36 step attenuator to PORT 1 SOURCE OUT	1	E8364-20053
W82	RF cable, A37 step attenuator to PORT 2 SOURCE OUT	1	E8364-20054

Table 1 Contents of Option UNL Upgrade Kit (E8364-60108)

Ref. Desig.	Description	Qty	Part Number
W83	RF cable, PORT 1 CPLR THRU to A38 bias tee	1	E8364-20039
W84	RF cable, PORT 2 CPLR THRU to A39 bias tee	1	E8364-20040
W99	RF cable, A45 reference switch to A28 channel R1 mixer	1	E8364-20154

Installation Procedure for the Upgrade Kit

The network analyzer must be in proper working condition prior to installing this option. Any necessary repairs must be made before proceeding with this installation.

WARNING **This installation requires the removal of the analyzer’s protective outer covers. The analyzer must be powered down and disconnected from the mains supply before performing this procedure.**

Electrostatic Discharge Protection

Protection against electrostatic discharge (ESD) is essential while removing or connecting cables or assemblies within the network analyzer.

Static electricity can build up on your body and can easily damage sensitive internal circuit elements when discharged. Static discharges too small to be felt can cause permanent damage. To prevent damage to the instrument:

- *always* wear a grounded wrist strap having a 1 MΩ resistor in series with it when handling components and assemblies.
- *always* use a grounded, conductive table mat while working on the instrument.
- *always* wear a heel strap when working in an area with a conductive floor. If you are uncertain about the conductivity of your floor, wear a heel strap.
- *always* ground yourself before you clean, inspect, or make a connection to a static-sensitive device or test port. You can, for example, grasp the grounded outer shell of the test port or cable connector briefly.

[Figure 1](#) shows a typical ESD protection setup using a grounded mat and wrist strap. Refer to [“Tools and Equipment Required for the Installation”](#) on [page 9](#) for part numbers.

Figure 1 ESD Protection Setup

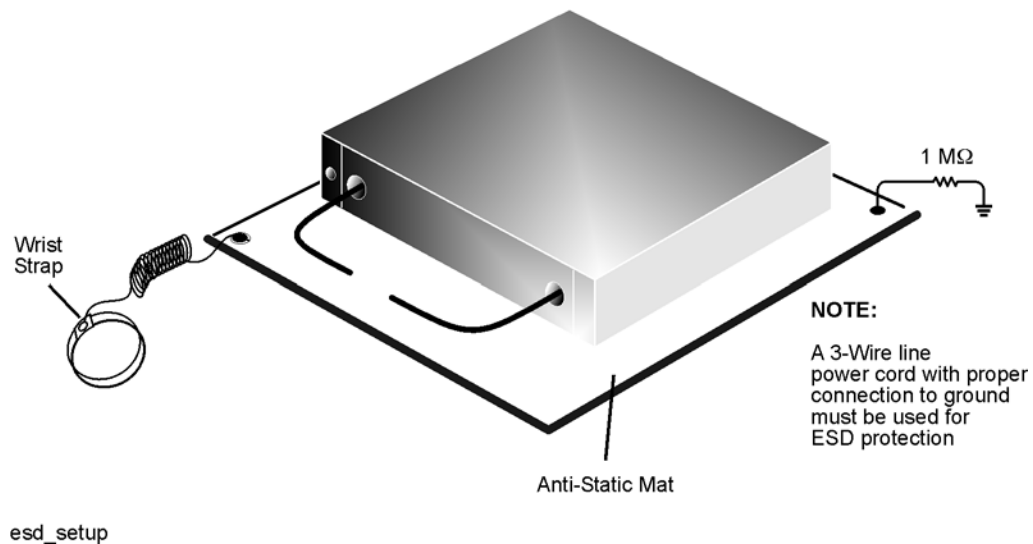

Overview of the Installation Procedure

- Step 1. Remove the Outer Cover.
- Step 2. Remove the Front Panel Assembly (Option 014 Only).
- Step 3. Raise the Receiver Deck.
- Step 4. Remove the Existing Cables.
- Step 5. Install the Attenuators and Bias Tees.
- Step 6. Install the Option UNL Cables.
- Step 7. Lower and Fasten the Receiver Deck and Connect the Bias Tee Control Cables.
- Step 8. Replace the Lower Front Panel Overlay (Option 014 Only).
- Step 9. Reinstall the Front Panel Assembly and Front Panel Jumpers (Option 014 Only).
- Step 10. Reinstall the Outer Cover.
- Step 11. Enable Option UNL.
- Step 12. Perform Post-Upgrade Adjustments and Calibration.

Tools and Equipment Required for the Installation

Description	Qty	Part Number
T-8 TORX driver (set to 5 in-lbs)	1	N/A
T-10 TORX driver (set to 9 in-lbs)	1	N/A
T-20 TORX driver (set to 21 in-lbs)	1	N/A
5/16-inch torque wrench (set to 10 in-lbs)	1	N/A
5/16-inch torque wrench (set to 21 in-lbs) (Option 014 only)	1	N/A
ESD grounding wrist strap	1	9300-1367
5-ft grounding cord for wrist strap	1	9300-0980
2 x 4 ft conductive table mat and 15-ft grounding wire	1	9300-0797
ESD heel strap (for use with conductive floors)	1	9300-1308

CAUTION Use a 5/16-inch torque wrench set to 10 in-lbs on all cable connections except the front-panel connectors to which the front-panel jumpers attach (Option 014). Use a 5/16-inch torque wrench set to 21 in-lbs for these connections.

Equipment Required for Post-Upgrade Adjustments

Equipment Type	Model or Part Number	Alternate Model or Part Number
Power meter	E4418B/E4419B	E4418A/E4419A
Power sensor, 2.4 mm	8487A	None
Adapter, 2.4 mm (f) to 2.4 mm (f)	11900B	85056-60007
RF cable, 2.4 mm (f) to 2.4 mm (f)	85133C	85133E

Step 1. Remove the Outer Cover

CAUTION This procedure is best performed with the analyzer resting on its front handles in the vertical position. *Do not place the analyzer on its front panel without the handles.* This will damage the front panel assemblies.

Refer to [Figure 2](#) for this procedure.

1. Disconnect the power cord (if it has not already been disconnected).
2. With a T-20 TORX driver, remove the strap handles (item ①) by loosening the screws (item ②) on both ends until the handle is free of the analyzer.
3. With a T-20 TORX driver, remove the four rear panel feet (item ③) by removing the center screws (item ④).
4. Slide the four bottom feet (item ⑤) off the cover.
5. Slide the cover off of the frame.

Figure 2 Outer Cover Removal

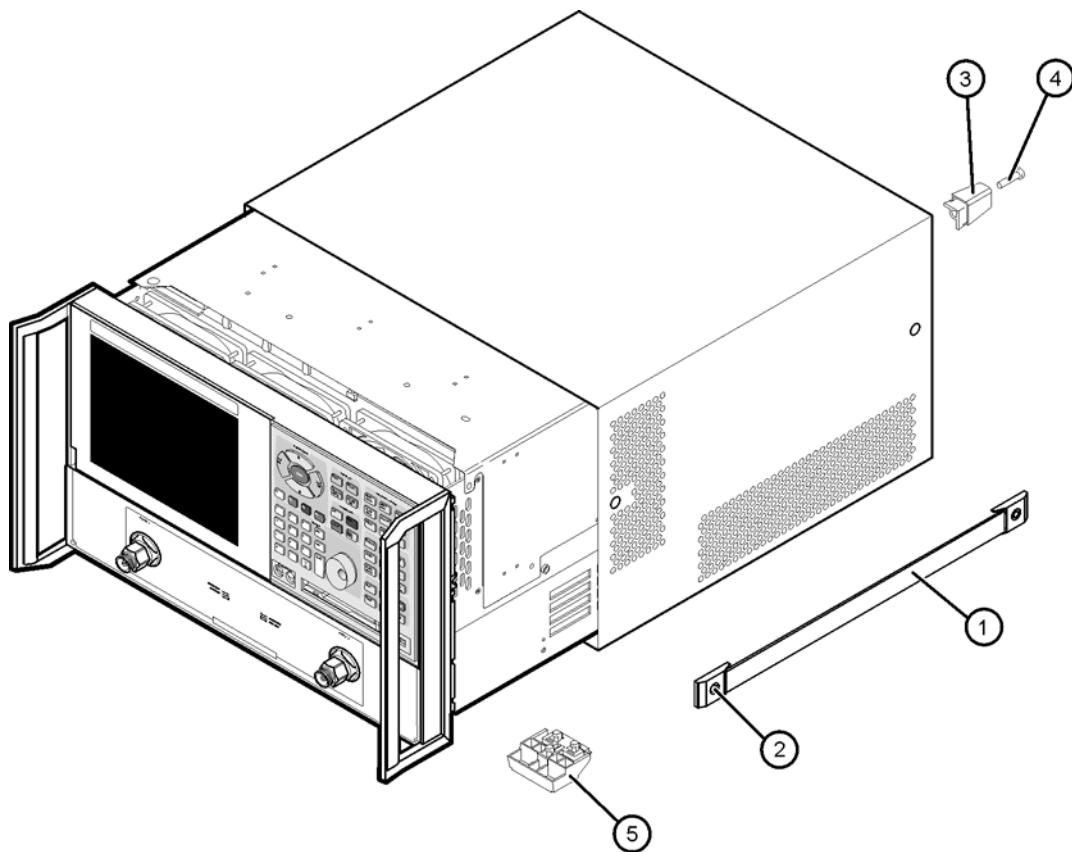

dt501a

Step 2. Remove the Front Panel Assembly (Option 014 Only)

Refer to [Figure 3](#) for this procedure.

1. With a 5/16-inch wrench, remove the six front panel semirigid jumper cables (item ①).
2. With a T-10 TORX driver, remove the eight screws (item ②) from the sides of the frame.

CAUTION Before removing the front panel from the analyzer, lift and support the front of the analyzer chassis.

3. Slide the front panel over the test port connectors.
4. Disconnect the front panel interface ribbon cable (item ③) from the A3 front panel interface board. The front panel is now free from the analyzer.

Figure 3 Front Panel Assembly Removal

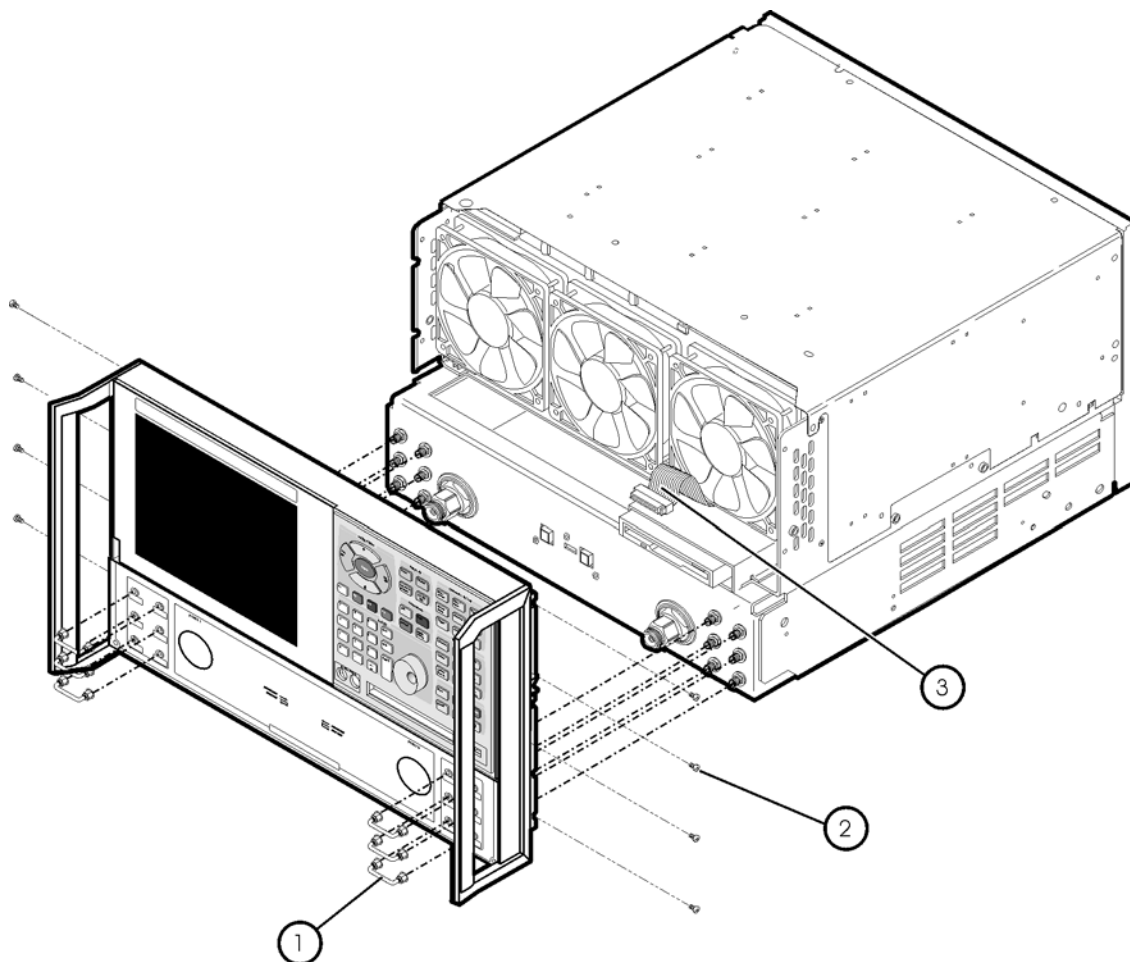

st536a

Step 3. Raise the Receiver Deck

Refer to [Figure 4](#) for this procedure.

1. Place the analyzer bottom-side up on a flat surface.
2. With a T-10 TORX driver, remove the four screws, (item ①), that secure the receiver deck.
3. Pull the latch pin (item ②) towards the opposite side of the analyzer to release the receiver deck.
4. Lift the receiver deck to partially raise it, then release the latch pin (item ②). Lift the receiver deck to its fully raised position and ensure that the latch pin latches in the raised position.

Figure 4 Receiver Deck, Raising

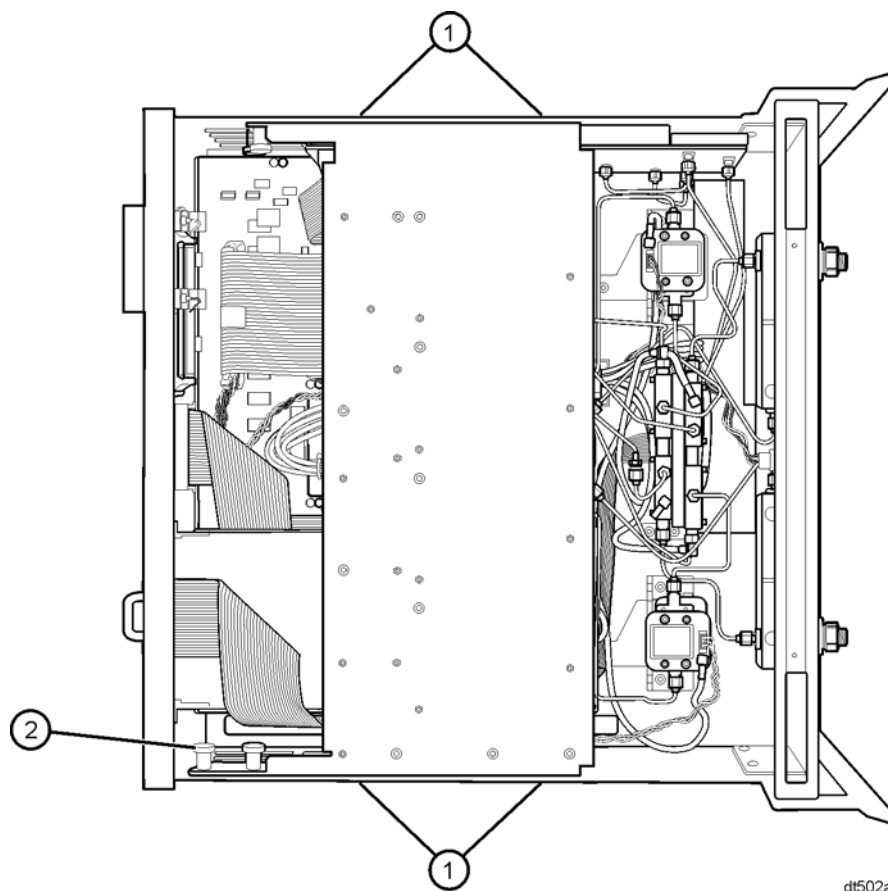

Step 4. Remove the Existing Cables

Analyzers WITHOUT Option 014

Refer to [Figure 5](#) for the following procedure.

Remove the following cables:

- W7 E8364-20025 A23 detector to A28 channel R1 mixer
- W8 E8364-20026 A24 detector to A29 channel R2 mixer
- W5 E8364-20021 A22 switch splitter to A25 test port 1 coupler
- W6 E8364-20022 A22 switch splitter to A26 test port 2 coupler

Figure 5 Cable Removal, Analyzers without Option 014

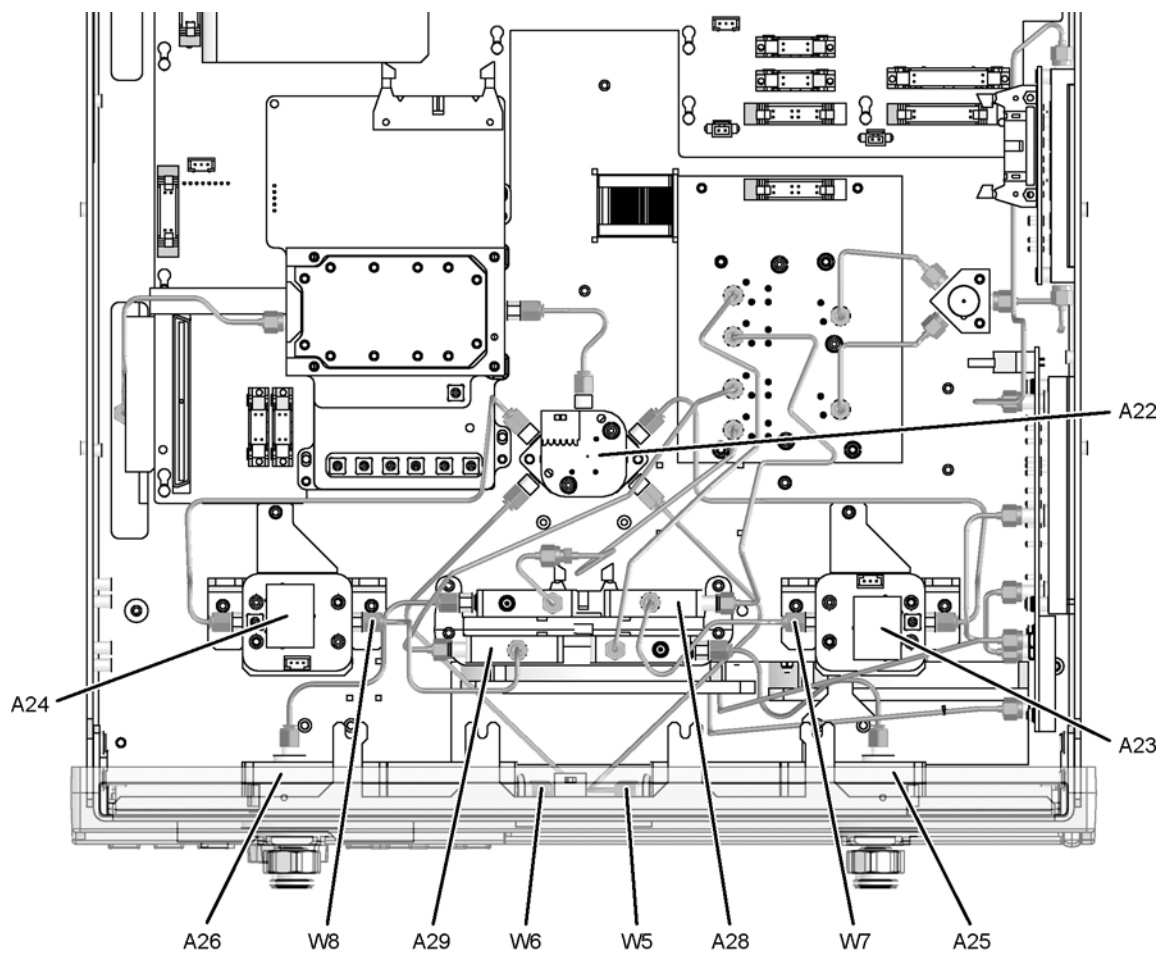

8364_025_01

Analyzers WITH Option 014 but WITHOUT Option 081

Refer to [Figure 6](#) for the following procedure.

Remove the following cables:

- W63 E8364-20073 PORT 1 CPLR THRU to A25 test port 1 coupler
- W61 E8364-20081 A22 switch splitter to PORT 1 SOURCE OUT
- W64 E8364-20074 PORT 2 CPLR THRU to A26 test port 1 coupler
- W62 E8364-20082 A22 switch splitter to PORT 2 SOURCE OUT
- W71 E8364-20076 REFERENCE 2 RCVR R2 IN to A29 channel R2 mixer
- W70 E8364-20075 REFERENCE 1 RCVR R1 IN to A28 channel R1 mixer

Figure 6 Cable Removal, Analyzers with Option 014 but without Option 081

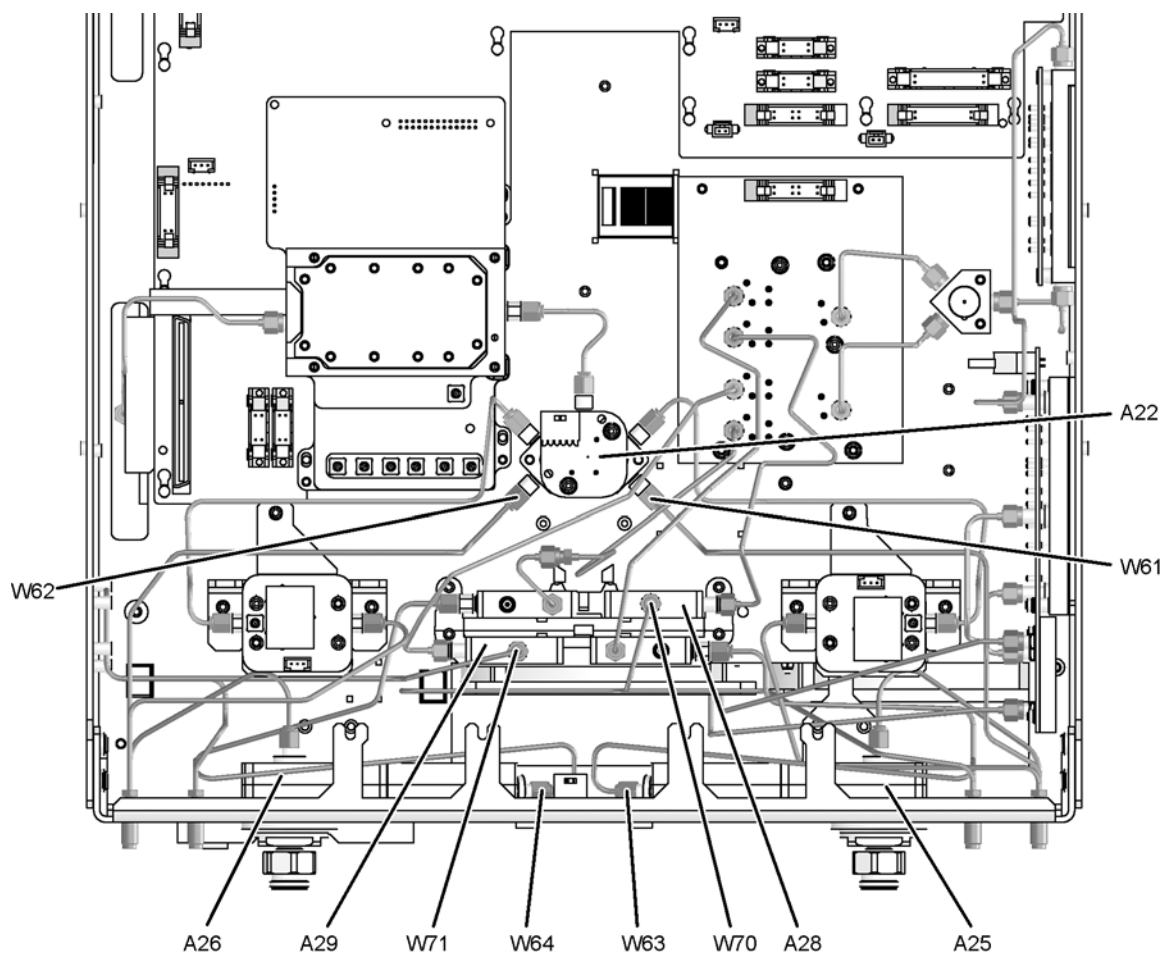

8364_025_02

Analyzers WITH Options 014 AND 081

Refer to [Figure 7](#) for the following procedure.

Remove the following cables:

- W63 E8364-20073 PORT 1 CPLR THRU to A25 test port 1 coupler
- W61 E8364-20081 A22 switch splitter to PORT 1 SOURCE OUT
- W67 E8364-20156 A25 test port 1 coupler to PORT 1 CPLR ARM
- W64 E8364-20074 PORT 2 CPLR THRU to A26 test port 1 coupler
- W62 E8364-20082 A22 switch splitter to PORT 2 SOURCE OUT
- W68 E8364-20157 A26 test port 2 coupler to PORT 2 CPLR ARM
- W71 E8364-20153 REFERENCE 2 RCVR R2 IN to A29 channel R2 mixer
- W99 E8364-20152 A45 reference switch to A28 channel R1 mixer

Figure 7 Cable Removal, Analyzers with Options 014 and 081

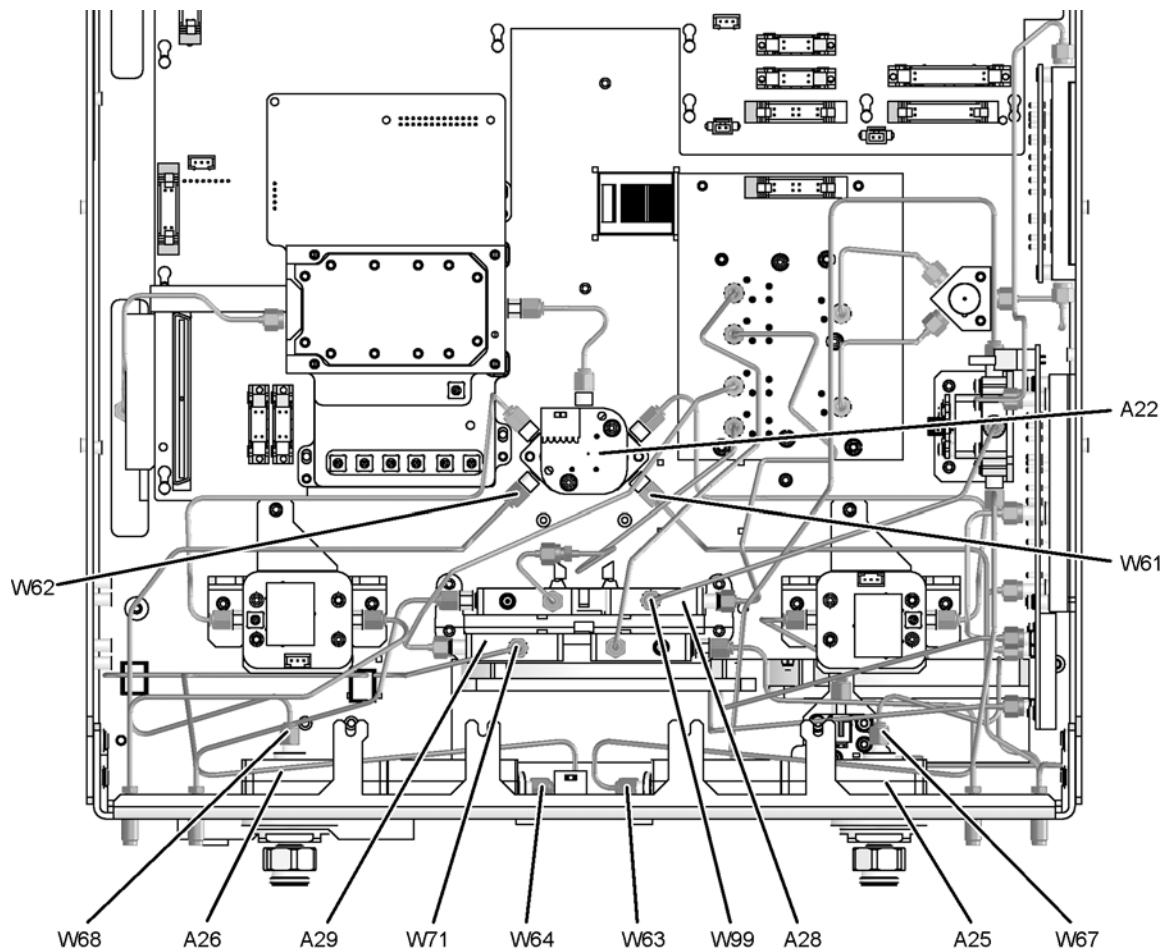

Step 5. Install the Attenuators and Bias Tees

Refer to [Figure 8](#) for this portion of the procedure.

To install the attenuators and bias tees, the brackets holding the detectors must be removed.

1. With a 5/16-inch torque wrench, disconnect, remove, and keep for reinstallation later, the two semirigid cables (item ①) from each detector. For analyzers without Option 014 installed, one of these cables has already been removed.
2. With a T-10 TORX driver, remove the three mounting screws (item ②) from each bracket holding the detector.
3. Remove the brackets from the analyzer with the detectors attached.

Figure 8 Attenuator and Bias Tee Installation, Bracket Removal

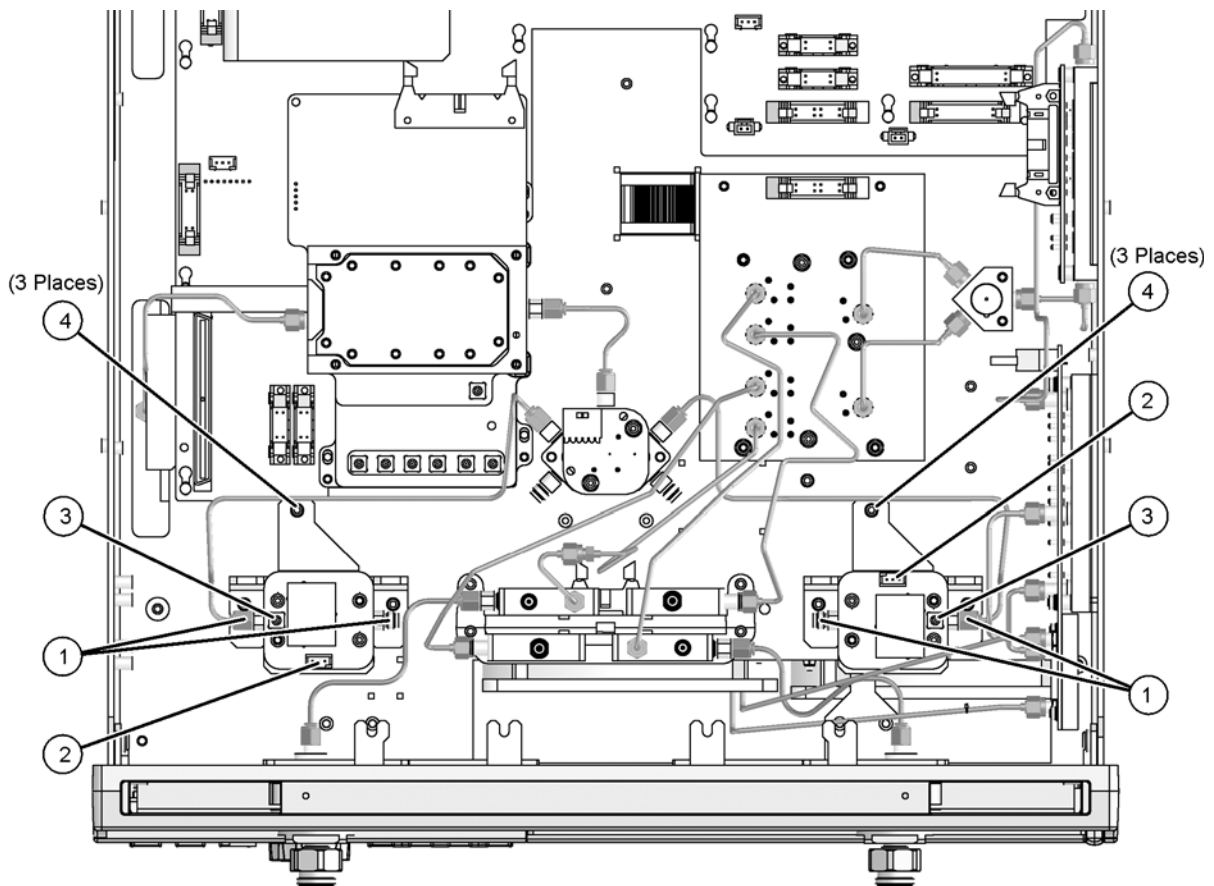

8364_025_04

Refer to [Figure 9](#) for this portion of the procedure.

4. Attach one step attenuator to each bracket using two M3.0 x 8 screws (provided) for each.

Be careful to position the step attenuators so that the necessary cables can be attached. The end of the step attenuator with the ribbon cable connector must face toward the inside of the analyzer. Review the cable connections in [Figure 9](#) if necessary.

5. Using a T-8 TORX driver, attach one bias tee to each bracket using two M2.5 x 14 screws (provided) for each.

The bias tees mount beneath the detectors. Be careful to position the bias tees so that the necessary cables can be attached. The end of the bias tee with the wires attached must face toward the inside of the analyzer. Review the cable connections in [Figure 9](#) if necessary.

6. Reinstall the brackets in the analyzer with the step attenuators, bias tees, and detectors attached.
7. Reconnect the stranded control cables, (item ①), and the flexible RF cables, (item ②) to the detectors.

Figure 9 Attenuator and Bias Tee Installation, Bracket Installation

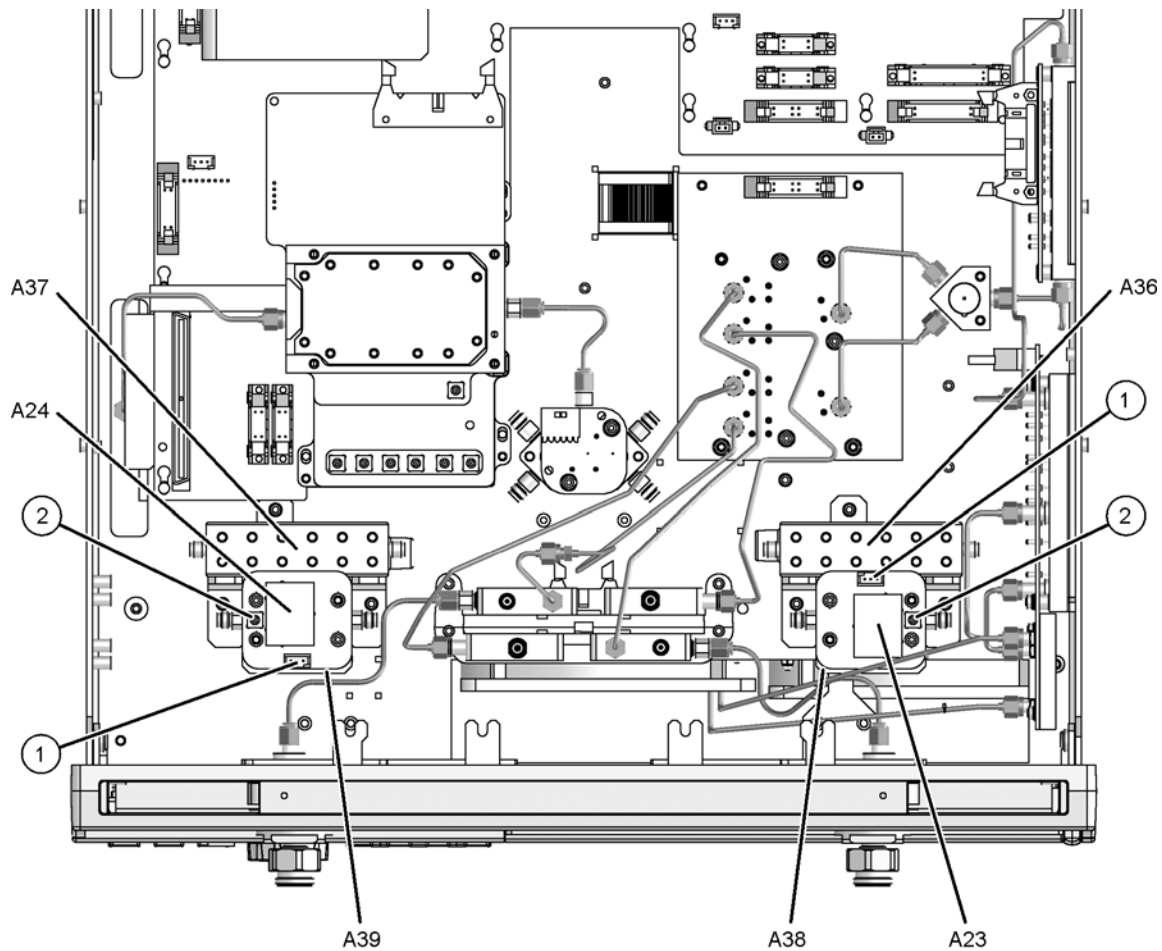

8364_025_05

Step 6. Install the Option UNL Cables

Analyzers WITHOUT Option 014

Refer to [Figure 10](#) for the following procedure. The new parts are listed in [Table 1 on page 4](#).

1. Install the following cables in the order listed:
 - Ribbon cable ① 8121-0819 A36 step attenuator to A16 motherboard (P1 SRC ATT)
 - Ribbon cable ② 8121-0119 A37 step attenuator to A16 motherboard (P2 SRC ATT)
 - W52 E8364-20056 A22 switch splitter to A37 step attenuator
 - W51 E8364-20055 A22 switch splitter to A36 step attenuator
 - W8 E8364-20175 Channel R2 detector to A29 channel R2 mixer
 - W7 E8364-20174 Channel R1 detector to A28 channel R1 mixer
 - W56 E8364-20168 A39 bias tee to A26 test port 2 coupler
 - W55 E8364-20167 A38 bias tee to A25 test port 1 coupler
 - W54 E8364-20077 A37 step attenuator to A39 bias tee
 - W53 E8364-20077 A36 step attenuator to A38 bias tee
2. Route the bias tee control cables through the cable clamp, (item ③), to the rear of the analyzer for connection to the A16 motherboard later.
3. Reinstall the semirigid cables, (item ④), to the detectors.

Figure 10 Cable Installation, Analyzers without Option 014

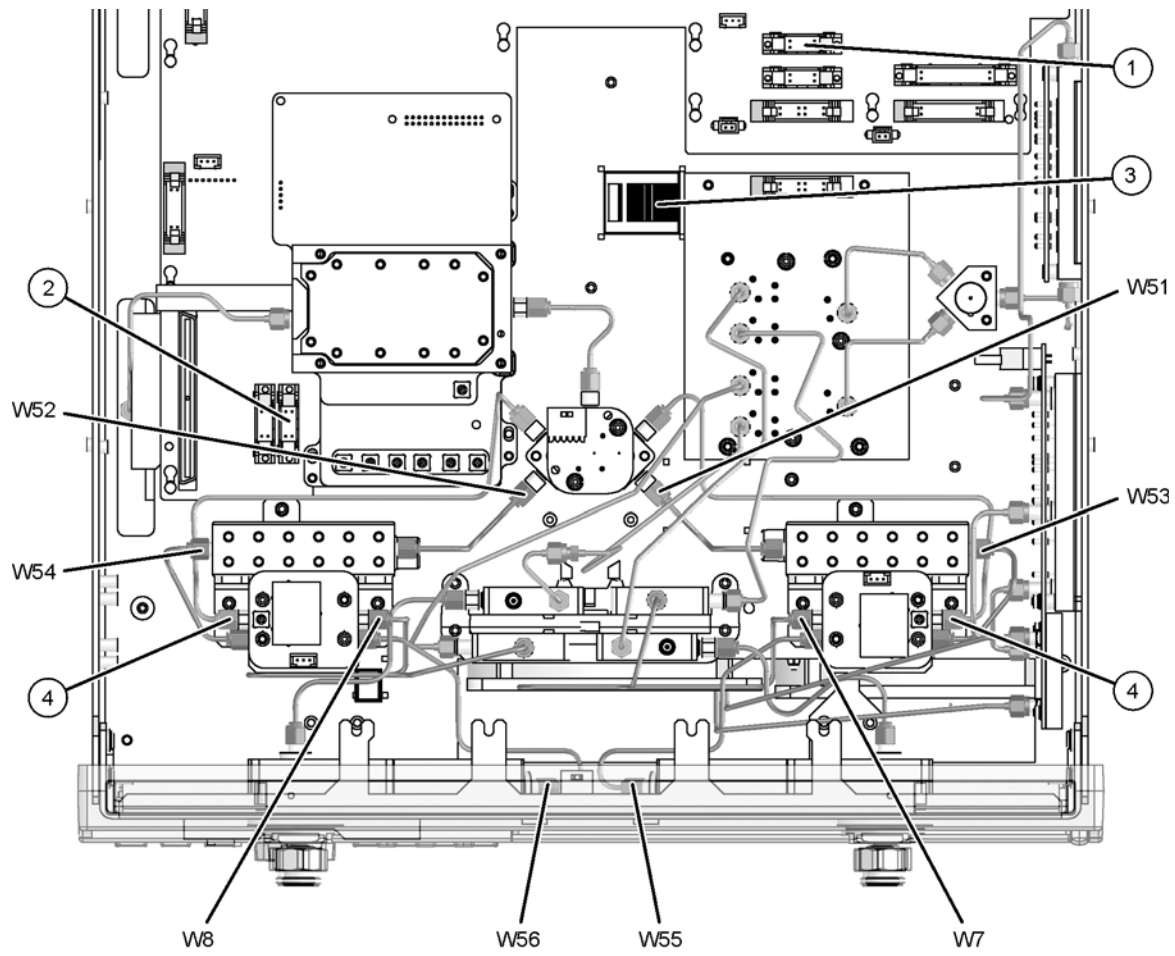

8364_025_06

Analyzers WITH Option 014 but WITHOUT Option 081

Refer to [Figure 11](#) for the following procedure. The new parts are listed in [Table 1 on page 4](#).

1. Install the following cables in the order listed:
 - Ribbon cable ① 8121-0819 A36 step attenuator to A16 motherboard (P1 SRC ATT)
 - Ribbon cable ② 8121-0119 A37 step attenuator to A16 motherboard (P2 SRC ATT)
 - W52 E8364-20056 A22 switch splitter to A37 step attenuator
 - W51 E8364-20055 A22 switch splitter to A36 step attenuator
 - W71 E8364-20177 REFERENCE 2 RCVR R2 IN to A29 channel R2 mixer
 - W70 E8364-20176 REFERENCE 1 RCVR R1 IN to A28 channel R1 mixer
 - W56 E8364-20168 A39 bias tee to A26 test port 2 coupler
 - W55 E8364-20167 A38 bias tee to A25 test port 1 coupler
 - W82 E8364-20054 A37 step attenuator to PORT 2 SOURCE OUT
 - W84 E8364-20040 PORT 2 CPLR THRU to A39 bias tee
 - W81 E8364-20053 A36 step attenuator to PORT 1 SOURCE OUT
 - W83 E8364-20039 PORT 1 CPLR THRU to A38 bias tee
2. Route the bias tee control cables through the cable clamp, (item ③), to the rear of the analyzer for connection to the A16 motherboard later.
3. Reinstall the semirigid cables, (item ④), to the detectors.

Figure 11 Cable Installation, Analyzers with Option 014 but without Option 081

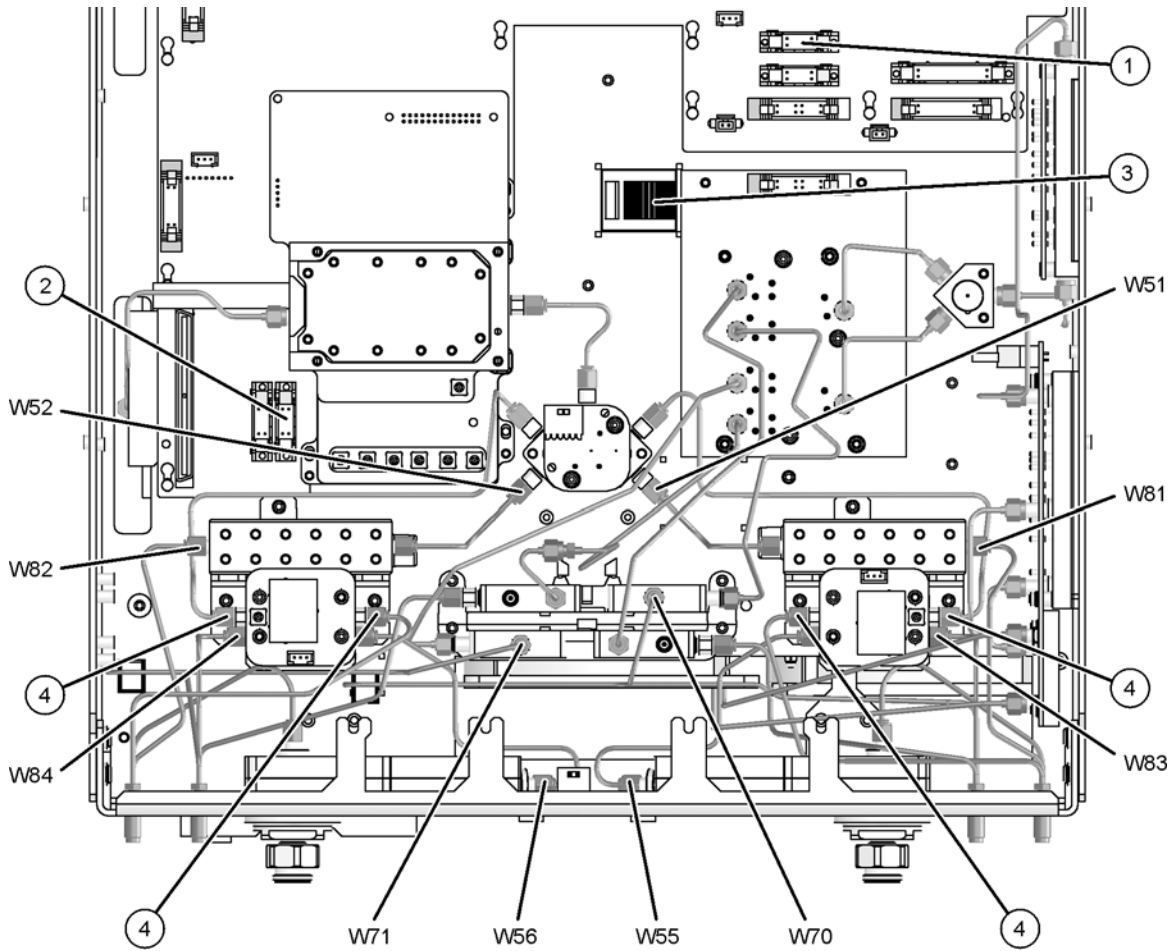

8364_025_07

Analyzers WITH Options 014 AND 081

Refer to [Figure 11](#) for the following procedure. The new parts are listed in [Table 1 on page 4](#).

1. Install the following cables in the order listed:
 - Ribbon cable ① 8121-0819 A36 step attenuator to A16 motherboard (P1 SRC ATT)
 - Ribbon cable ② 8121-0119 A37 step attenuator to A16 motherboard (P2 SRC ATT)
 - W52 E8364-20056 A22 switch splitter to A37 step attenuator
 - W51 E8364-20055 A22 switch splitter to A36 step attenuator
 - W71 E8364-20015 REFERENCE 2 RCVR R2 IN to A29 channel R2 mixer
 - W99 E8364-20154 A45 reference switch to A28 channel R1 mixer
 - W56 E8364-20168 A39 bias tee to A26 test port 2 coupler
 - W55 E8364-20167 A38 bias tee to A25 test port 1 coupler
 - W68 E8364-20044 A26 test port 2 coupler to PORT 2 CPLR ARM
 - W82 E8364-20054 A37 step attenuator to PORT 2 SOURCE OUT
 - W84 E8364-20040 PORT 2 CPLR THRU to A39 bias tee
 - W67 E8364-20043 A25 test port 1 coupler to PORT 1 CPLR ARM
 - W81 E8364-20053 A36 step attenuator to PORT 1 SOURCE OUT
 - W83 E8364-20039 PORT 1 CPLR THRU to A38 bias tee
2. Route the bias tee control cables through the cable clamp, (item ③), to the rear of the analyzer for connection to the A16 motherboard later.
3. Reinstall the semirigid cables, (item ④), to the detectors.

Figure 12 Cable Installation, Analyzers with Options 014 and 081

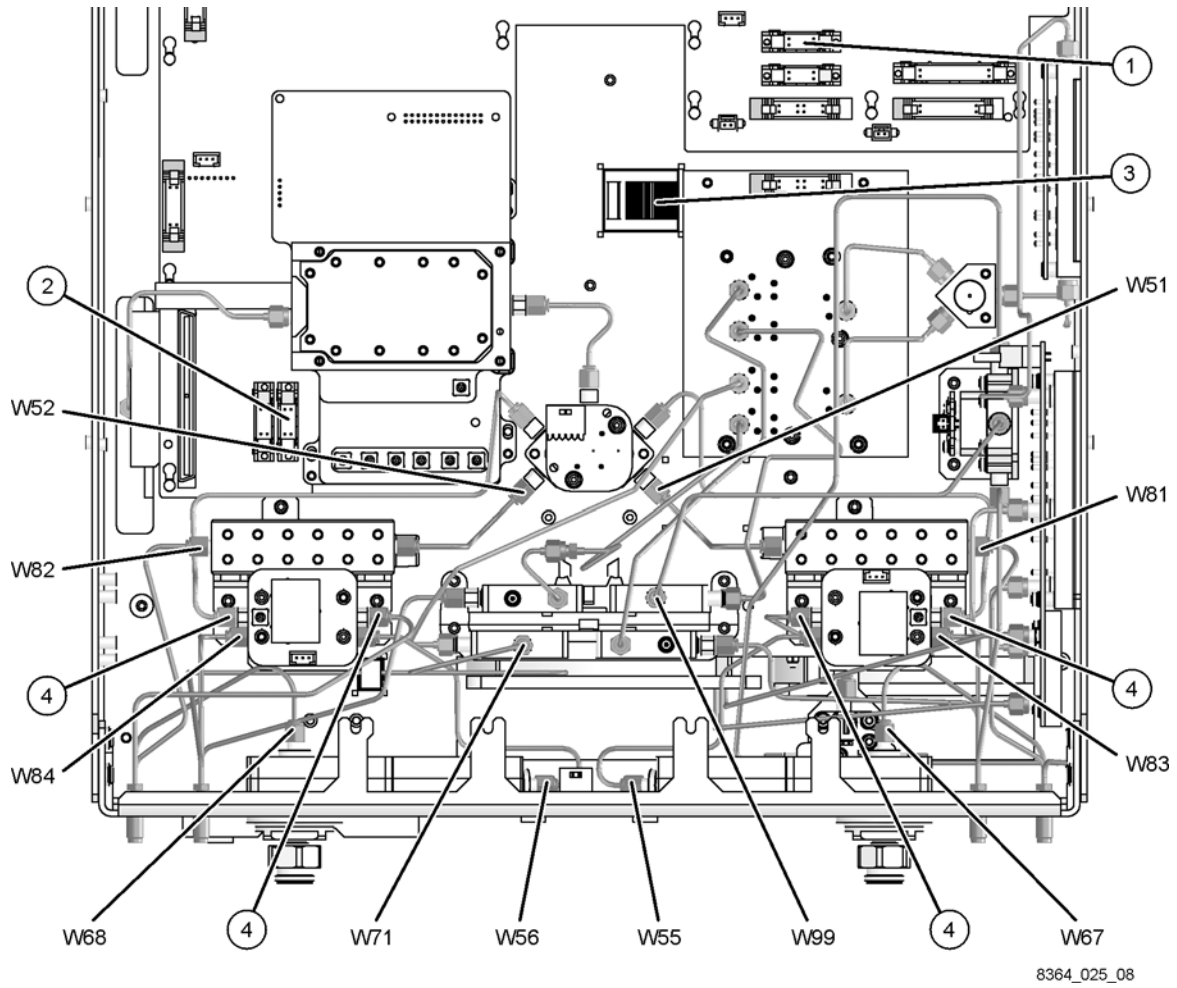

Step 7. Lower and Fasten the Receiver Deck and Connect the Bias Tee Control Cables

Refer to [Figure 13](#) for this procedure.

1. Pull the latch pin (item ②) toward the center of the analyzer to release the receiver deck.
2. Lift the receiver deck to partially lower it, then release the latch pin (item ②). Lower the receiver deck to its fully lowered position and ensure that the latch pin latches in the lowered position.
3. With a T-10 TORX driver, install the four screws (item ①) to secure the receiver deck.
4. Connect the bias tee cables to the A16 motherboard connectors as indicated.
5. The dc bias input connectors and fuse holders (fuses included) are already installed on the rear panel but covered. Using a T-10 TORX driver, remove the four screws from the cover and remove and discard the cover.

Figure 13 Receiver Deck, Lowering

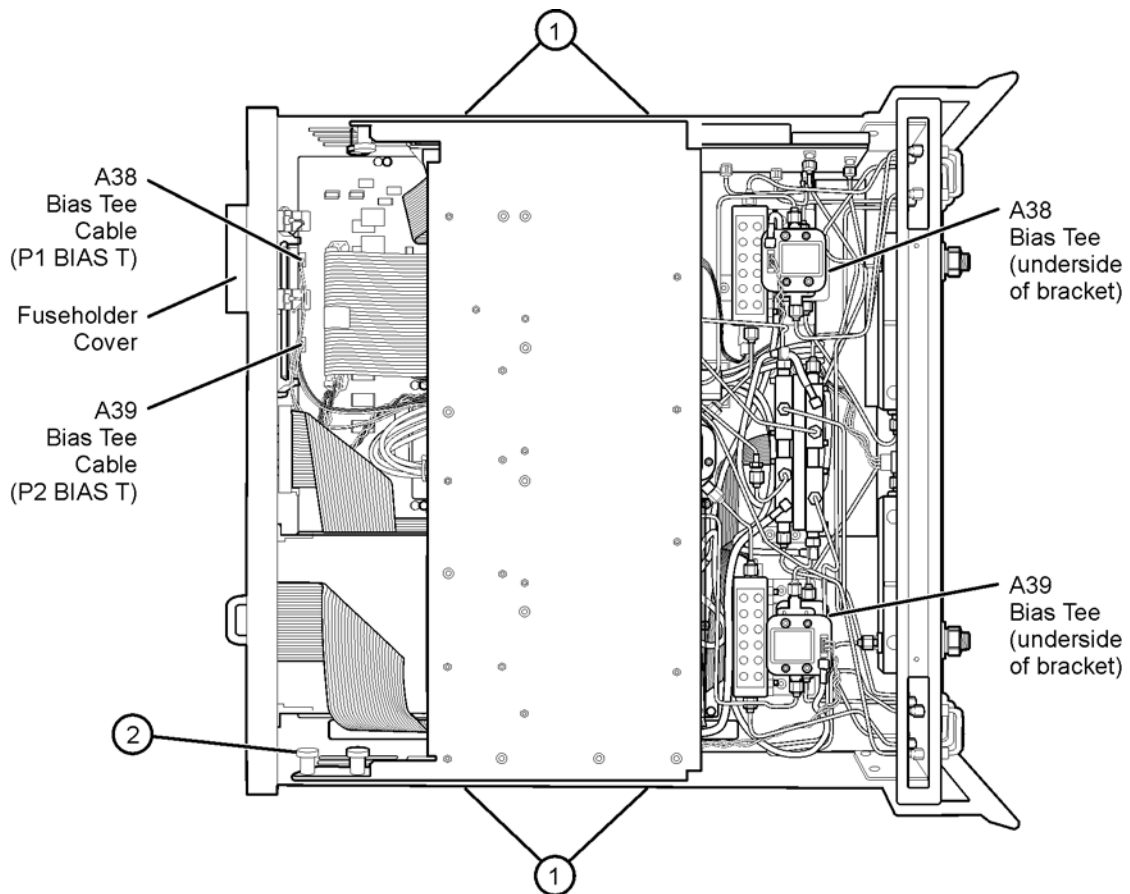

8364_025_09

Step 8. Replace the Lower Front Panel Overlay (Option 014 Only)

NOTE The new parts referenced in this procedure are listed in [Table 1 on page 4](#).

Refer to [Figure 14](#) for this procedure.

1. From the back side of the front panel, use a blunt object in one of the cutouts in the frame to push the overlay (item ①) and separate it from the front panel.
2. From the front side of the front panel, pull the overlay completely off and discard it.
3. Remove any adhesive remaining on the front panel.
4. Remove the protective backing from the new Option 014 front panel overlay (item ①).
5. Starting from either the left or right side, *loosely* place the overlay in the recess on the lower front panel, ensuring that it fits tightly against the recess edges.
6. Once the overlay is in place, press it firmly onto the frame to secure it.

Figure 14 Lower Front Panel Overlay Replacement

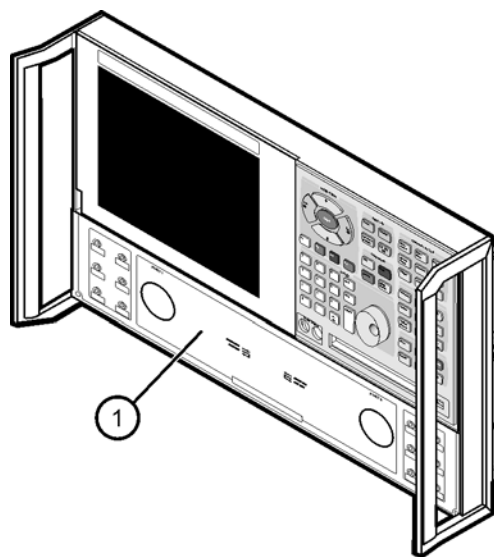

dt510a

Step 9. Reinstall the Front Panel Assembly and Front Panel Jumpers (Option 014 Only)

CAUTION Before installing the front panel assembly onto the analyzer, lift and support the front of the analyzer chassis.

Refer to [Figure 15](#) for this procedure.

1. Tighten all 12 of the front-panel feed-through connectors using a 5/16-inch torque wrench set to 21-in lbs.
2. Reconnect the ribbon cable (item ③) to the A3 front panel interface board.
3. Slide the front panel over the test port connectors being careful to align the power switch and floppy disk drive to their corresponding front panel cutouts. Ensure that the ribbon cable (item ③) is located below the fan to prevent it from being damaged by the fan blades.
4. With a T-10 TORX driver, install the eight screws (item ②) in the sides of the frame.
5. Install the six semirigid jumpers (item ①) on the front panel and tighten to 10-in lbs.

Figure 15 Front Panel Assembly Reinstallation

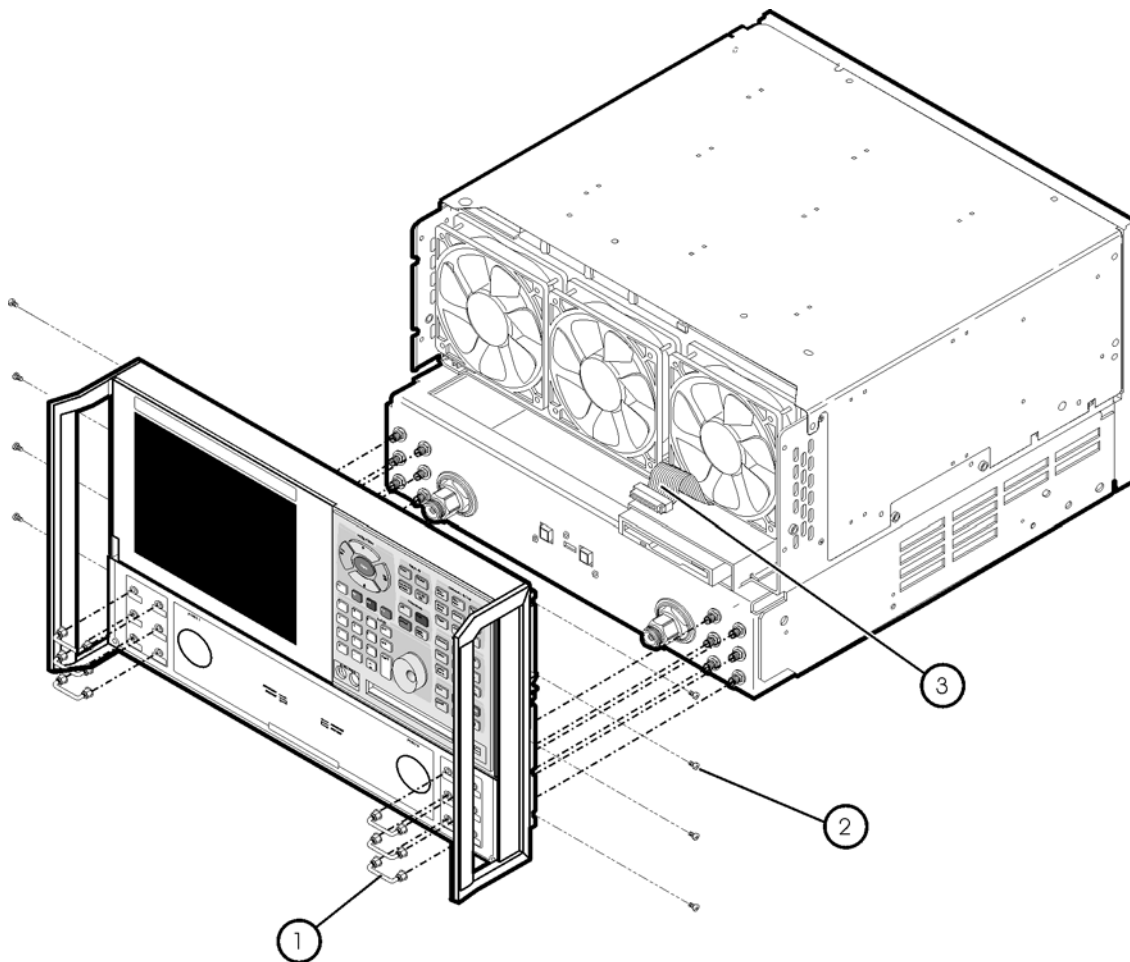

st536a

Step 10. Reinstall the Outer Cover

CAUTION This procedure is best performed with the analyzer resting on its front handles in the vertical position. *Do not place the analyzer on its front panel without the handles.* This will damage the front panel assemblies.

Refer to [Figure 16](#) for this procedure.

1. Slide the cover over the analyzer frame.
2. With a T-20 TORX driver, install the four rear panel feet (item ③) by installing the center screws (item ④).
3. Slide the four bottom feet (item ⑤) into position on the cover.
4. With a T-20 TORX driver, install the strap handles (item ①) by installing the screws (item ②) on both ends of the handles.

Figure 16 Outer Cover Reinstallation

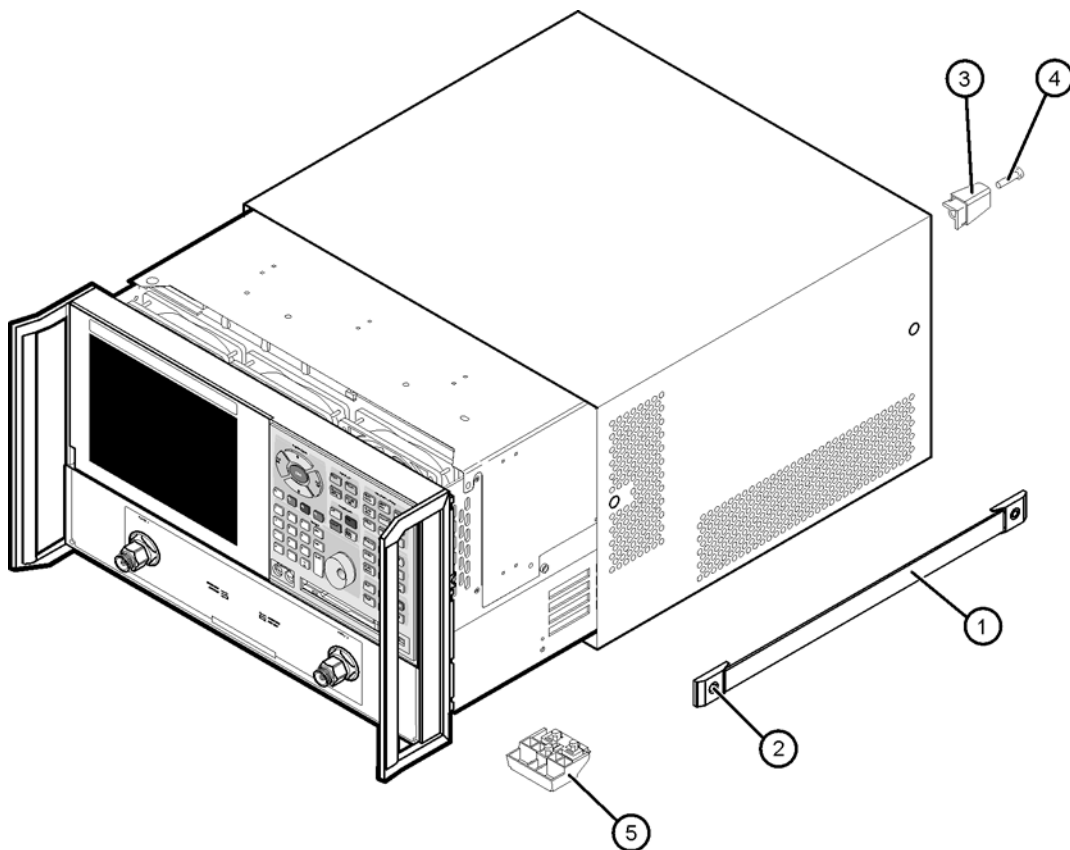

dt501a

Step 11. Enable Option UNL

Procedure Requirements

- The analyzer must be powered up and operating to perform this procedure.
- The Network Analyzer program must be running.
- A mouse is required.

Enable Option UNL

1. On the analyzer's **System** menu, point to **Service**, and then click **Option Enable**.
2. In the **Select Desired Option** list, click **UNL - Bias Tees w/Atten**.
3. Click **Enable**.
4. Click **Yes** in answer to the displayed question in the **Restart Analyzer?** box.
5. When the installation is complete, click **Exit**.

Verify that Option UNL is Enabled

1. On the analyzer's **Help** menu, click **About Network Analyzer**.
2. Verify that "UNL" is listed after "Options:" in the display.
3. Click **OK** when done.

NOTE If Option UNL has not been enabled, perform ["Enable Option UNL"](#) again. If the option is still not enabled, contact Agilent Technologies. Refer to ["Getting Assistance from Agilent"](#) on page 3.

Step 12. Perform Post-Upgrade Adjustments and Calibration

The following adjustments must be made due to the change in the full frequency range of the analyzer.

- source calibration
- receiver calibration

These adjustments are described in the PNA service guide and in the PNA on-line HELP. A list of equipment required to perform these adjustments can be found at [“Equipment Required for Post-Upgrade Adjustments” on page 9](#).

Performance Tests and System Verification

The analyzer should now operate and phase lock over its entire frequency range.

If you experience difficulty with the basic functioning of the analyzer, contact Agilent. Refer to [“Getting Assistance from Agilent” on page 3](#).

Although the analyzer functions, its performance relative to its specifications has not been verified for the additional frequency range enabled by this upgrade.

It is recommended that a full instrument calibration be performed using the PNA performance test software.

If the testing of the analyzer’s full range of specifications is not required, a system verification can be performed.

Refer to the analyzer’s service guide for information on performance tests and system verification.

